

***Read this page and the complete instructions before attempting to operate your
TWISTER SPEED LATHE.***

We urge you to review the following warnings, procedures and operations. All persons involved in setting up, operating, or servicing the machine are required to **be sufficiently qualified, read and understand this manual and its contents.**

If you have any questions about this machine, call us toll free at 1-800-362-4567.

We strongly suggest that anyone who will set-up, operate, or be in the vicinity of the *Twister Speed Lathe* while it is being used should read all of the following recommendations:

- ✓ NEVER attempt to operate this machine in a damp or wet area.
- ✓ NEVER attempt to operate this machine without first having its installation and your set-up checked out by a person qualified to do so. Always disconnect this machine from power source when servicing or maintaining.
- ✓ NEVER use chucks or fixtures in this machine.
- ✓ DO NOT allow any material or part to protrude more than three (3) inches beyond either end of the spindle at any time.
- ✓ NEVER leave this machine unattended while it is running.
- ✓ DO NOT attempt to polish or deburr out-of-balance or out-of-round parts.
- ✓ DO NOT operate this machine while wearing a ring, a watch, jewelry, a tie, loose clothing, or long hair, which is not contained by a net, or shop cap.
- ✓ NEVER wear gloves while operating this machine.
- ✓ NEVER open or close the Collet closer while the spindle is rotating.
- ✓ NEVER start the machine unless the Collet is closed.
- ✓ ALWAYS wear safety glasses and respiratory protection.

1. Safety and Safeguards

1.1 Dangers Associated With This Machine

The *Twister Speed Lathe* is designed exclusively for the applications outlined in this manual. Any circumstances interfering with the safe use of the machine are to be remedied immediately.

1.2 Appropriate Use of This Machine

The *Twister Speed Lathe* is designed and intended for sanding, polishing, deburring, filing, scraping, gauging and assembly operations.

1.3 Emissions

The *Twister Speed Lathe* has an operational noise level of approximately 68 db(A). Also, there are dusts and fumes associated with polishing and sanding materials.

1.4 Hazards and Dangers

Warning! The *Twister Speed Lathe* has unguarded, spinning parts including:

Any attached work holding devices (collets), the collet closer assembly and knurled ring. Those parts and assemblies can inflict injury to hands and fingers, and eyes. Insufficient clamping force on a part or an unbalanced part that may be thrown off the machine can cause serious injury.

1.5 Safety Requirements during Use

To avoid accidents by inadvertently knocking the *Twister Speed Lathe* off the bench, it is recommended to bolt down the machine.

1.6 Machine Safeguards

The *Twister Speed Lathe* can be turned off with the **ON-OFF** switch.

1.7 Qualified Personnel

All personnel setting up or operating the *Twister Speed Lathe* have to be qualified and authorized to do so. The owner's manual has to be provided to the operator. It is the owner's responsibility to ascertain the operator's understanding of the manual.

1.8 Personal Safety Equipment

Safety glasses are required during the operation of the *Twister Speed Lathe*. Wearing gloves of any kind is prohibited while operating the *Twister Speed Lathe*.



2 Installation

Have you read and understood Section 1, *Safety and Safeguards*? The machine may not be operated without doing so.



The foot switch will start the LT-1BR or the LT-2AR any time the power switch is turned on!

2.1 Setting up and mounting the LT-1BR (See figure 1)

The LT-1BR MUST be removed from the shipping base before using it or belt slippage will result.

- a) Set up the **LT-1BR** where you need it, making sure it is placed on a clean, dry and level surface. Do not place it closer than five inches to the edge of the mounting surface to minimize accidental contact by surrounding personnel.
- b) The machine can be fastened down with a 5/16-18 fastener screwed into a tapped hole on the bottom of the machine. Drill a 5/16 hole through the mounting surface approximately 13 inches from the front edge and located from side-to-side so that it will line up with the center of your **LT-1BR**. Select a fastener that has a length equal to the thickness of the mounting surface plus 1-1/4". Tighten the fastener so it is snug not tight (five foot-pounds maximum).

Too tight will result in belt slippage. The fastener must not protrude more than 1.50 inches above the mounting surface or it will damage the motor.

2.2 Setting up and mounting the LT-2AR (See figure 2)

- a) Set up the **LT-2AR** where you need it, making sure it is placed on a clean, dry and level surface. Do not place it closer than five inches to the edge of the mounting surface to minimize accidental contact by surrounding personnel.
- b) The **LT-2AR** has three .50 inch diameter holes available to fasten it down. Since the casting is a lightweight aluminum alloy, care must be exercised not to distort it when bolting it down. If you are attaching it to a workbench we recommend rubber pads under the **LT-2AR** and rubber bushings around the .25 diameter fasteners. They should only be tightened enough to slightly compress the rubber so the **LT-2AR** has no lateral movement. If you are mounting to a flat, machined surface no rubber pads are needed; simply fasten down the **LT-2AR** using 3/8 inch fasteners. Torque them to ten foot-pounds.

3 Operation

Have you read and understood Section 1, *Safety and Safeguards*? The machine may not be operated without doing so.

3.1 Collet Specifications for all Models

The 5-C collets used in all models must conform to the drawings in **Figures 3** and **4**. The two most important features are the 1.2500 inch diameter and the width of the thread relief. If your collets have a thread relief wider than **.100 inch** you risk the collet rotating and allowing the spindle key to get permanently stuck in the thread relief. If this happens your unit will require factory repair. We strongly recommend using only collets that meet these specifications. Oversize 5-C collets up to three-inch diameter may be used in the *Twister Speed Lathe*. The collets **must** have the 10° taper as shown in **Figure 3**.

3.2 Adjusting the Collet Tension

- a) Make sure the **POWER** switch is **OFF** !
- b) Insert the Collet into the spindle and rotate the collet to align its keyway with the spindle key. **COLLET AND SPINDLE BORE MUST BE CLEAN!** Slide the closer handle (Fig. 5) to the right.
- c) Release the adjusting finger (Fig. 5) by pressing it down into the collet closer depression.
- d) With your left hand rotate the knurled knob (Fig. 5) clockwise while pressing inward to engage the collet threads. Use your right hand to prevent the collet from getting pushed out of the spindle. Thread on two (2) turns only.
- e) Insert a workpiece into the collet and push the closer handle to the left. Then continue rotating the knurled drawtube clockwise until it gets snug. Should the spindle begin to rotate, push and hold the spindle lock (Fig. 5.) It will engage in the spindle to prevent rotation.
- f) Move the closer handle all the way to the right and rotate the collet closer clockwise two to four more notches on the sector plate (Fig. 5). Check that the collet is gripping the workpiece with the desired firmness by moving the closer handle to the left.
- g) Lock the collet closer adjustment by pushing down on the right side of the adjusting finger while making sure the finger engages into a notch in the sector plate.
- h) The machine is now ready for processing a workpiece.

3.3 Start and Stop the Spindle using the BRAKE-RUN switch

- a) After the part is firmly locked in the collet, turn the **POWER** switch to **ON**, set the **SPINDLE ROTATION** switch to **NORMAL** or **REVERSE**, and turn the **BRAKE-RUN** switch to **RUN**.
- b) Select the desired speed by turning the **SPINDLE SPEED** knob.
- c) In order to stop the spindle, move the **BRAKE-RUN** switch to the **BRAKE** position.

3.4 Start and Stop the Spindle with the Foot Switch

- a) If the foot switch is being used, leave the **BRAKE-RUN** switch in the **BRAKE** position. Press the foot switch for **RUN**, and release it for **BRAKE**.

3.5 Changing the Spindle Direction

- a) Push the **SPINDLE ROTATION** switch to the desired indicated direction.

3.6 Operational Notes

Generally, polishing is done at high speeds, deburring at low speeds; the bigger the part diameter, the lower the speed needed. Select a slow speed for filing and scraping without chatter. If chatter becomes a problem make sure your scraper is very sharp and, if necessary, reduce the spindle speed. Polishing is usually done at as fast a spindle speed as possible without burning or smearing the part or sandpaper.

Remember your *Twister* normally functions smoothly and easily. If a collet will not fit or parts can not be gripped without constant readjustments (assuming parts do not vary in size), check for dirty or damaged collet threads or a badly worn collet. Keep the collet and drawbar threads clean to eliminate potential problems.

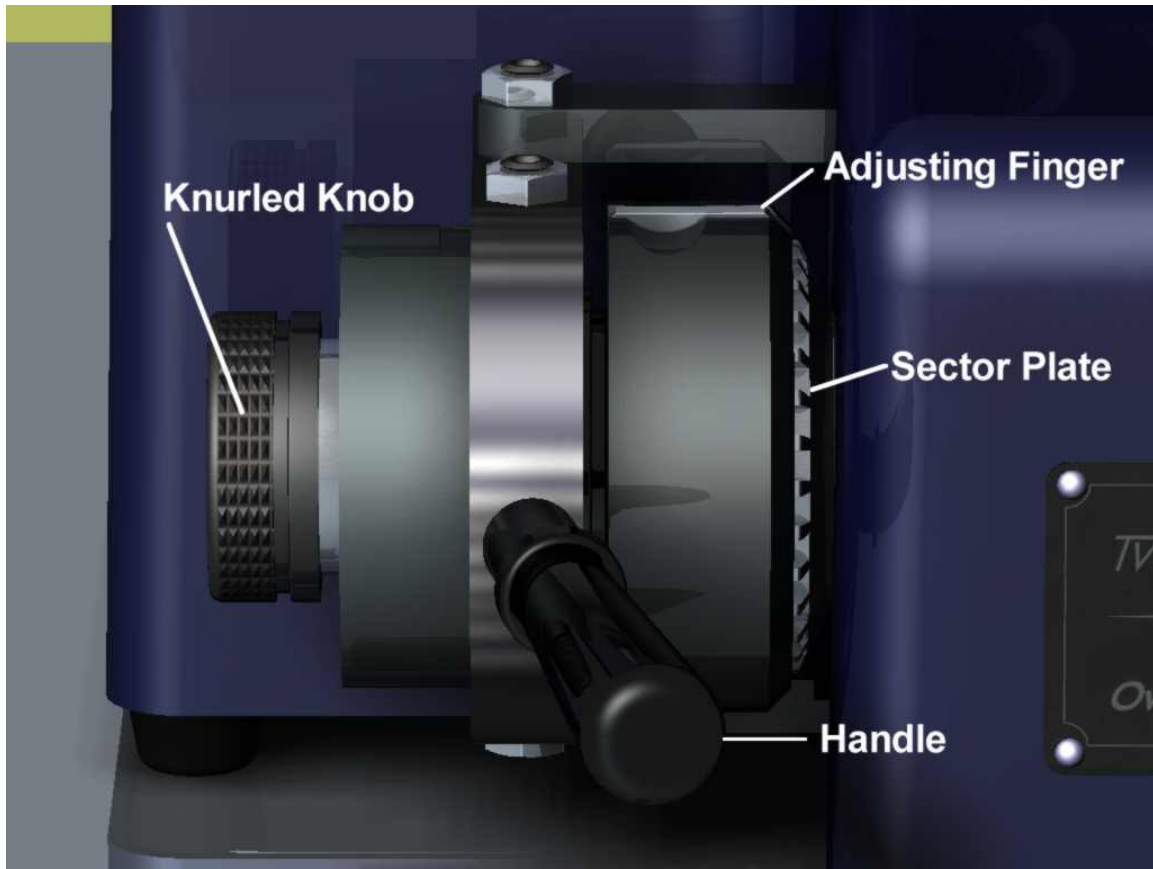

FIGURE 5

W a r r a n t y

All models of the **TWISTER SPEED LATHE** are warranted against defects in workmanship and materials for a period of six (6) months from date of purchase.

Overbeck Machine Tools will, under warranty, provide free service at the factory, including parts, labor, and (*continental U.S. only*) UPS® *Ground Service* back to the customer after warranty repair. Returned units should be packed in the original shipping carton. Please call prior to returning a unit for either warranty or non-warranty service. We may be able to save you the inconvenience of shipping the unit back to us.

Machines sold outside the contiguous United States:

Overbeck Machine Tools will provide free service at the factory. However, the customer is responsible for all freight and customs costs both to and from the factory.

Shipments should be sent *freight prepaid* and *insured for replacement cost* to:

Overbeck Machine Tools
2620 Mission Street
Santa Cruz, California 95060
Telephone (831) 425-5912 | FAX (831) 423-9363 | www.overbeckmachine.com

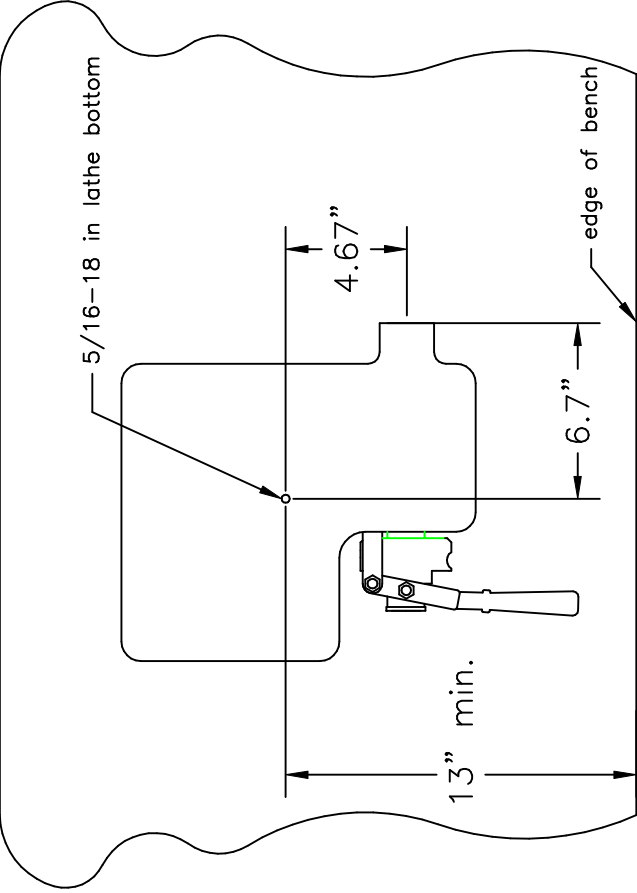

FIGURE 1

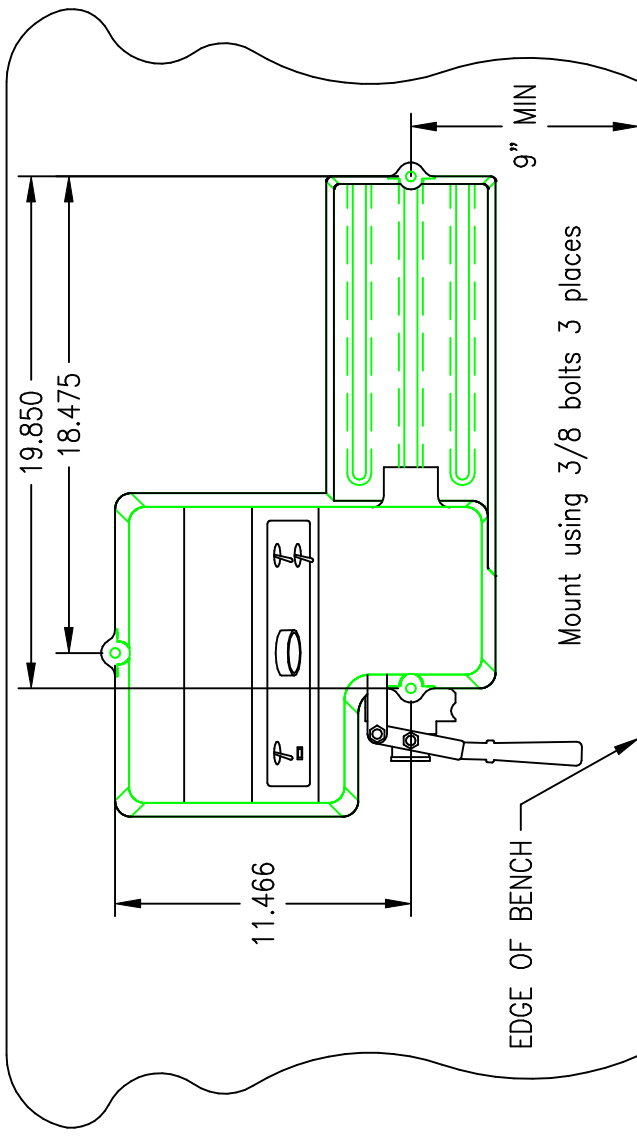

FIGURE 2

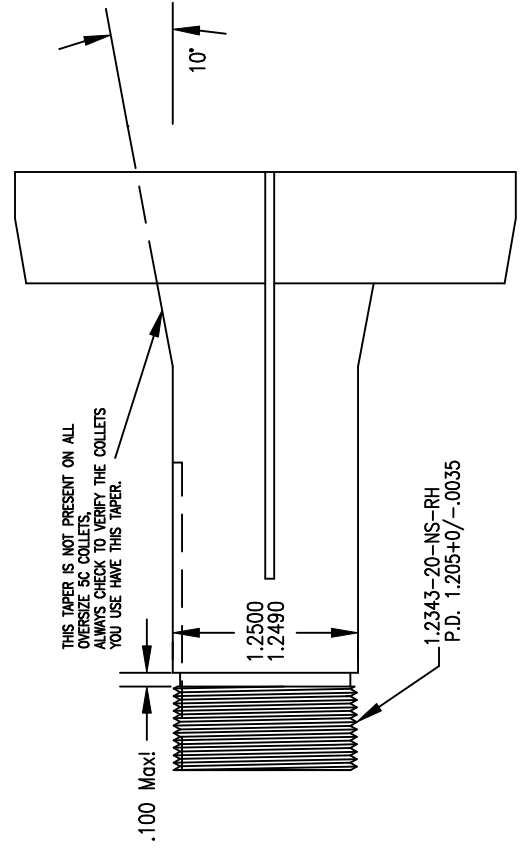

FIGURE 3

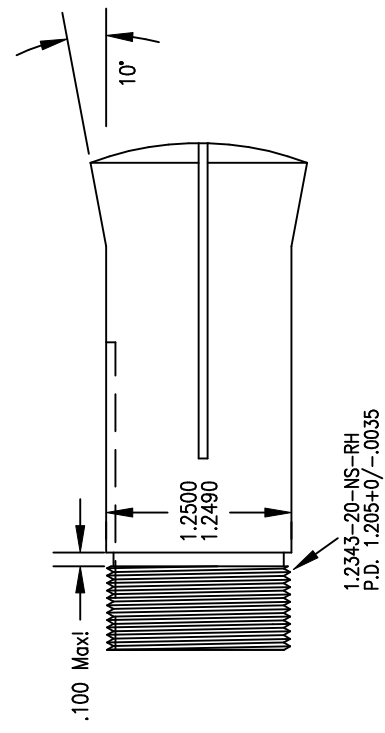

FIGURE 4