

4

3

2

1

REVISION HISTORY			
REV	DESCRIPTION	APPROVED	DATE
-			

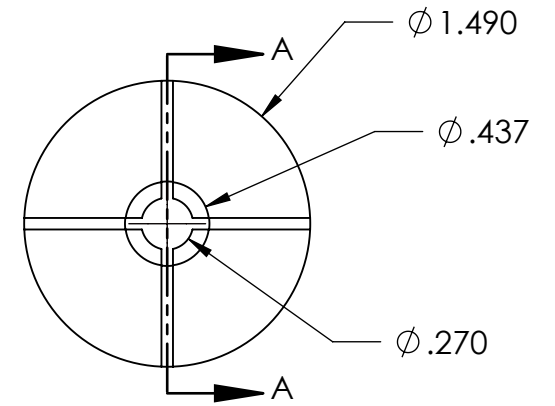
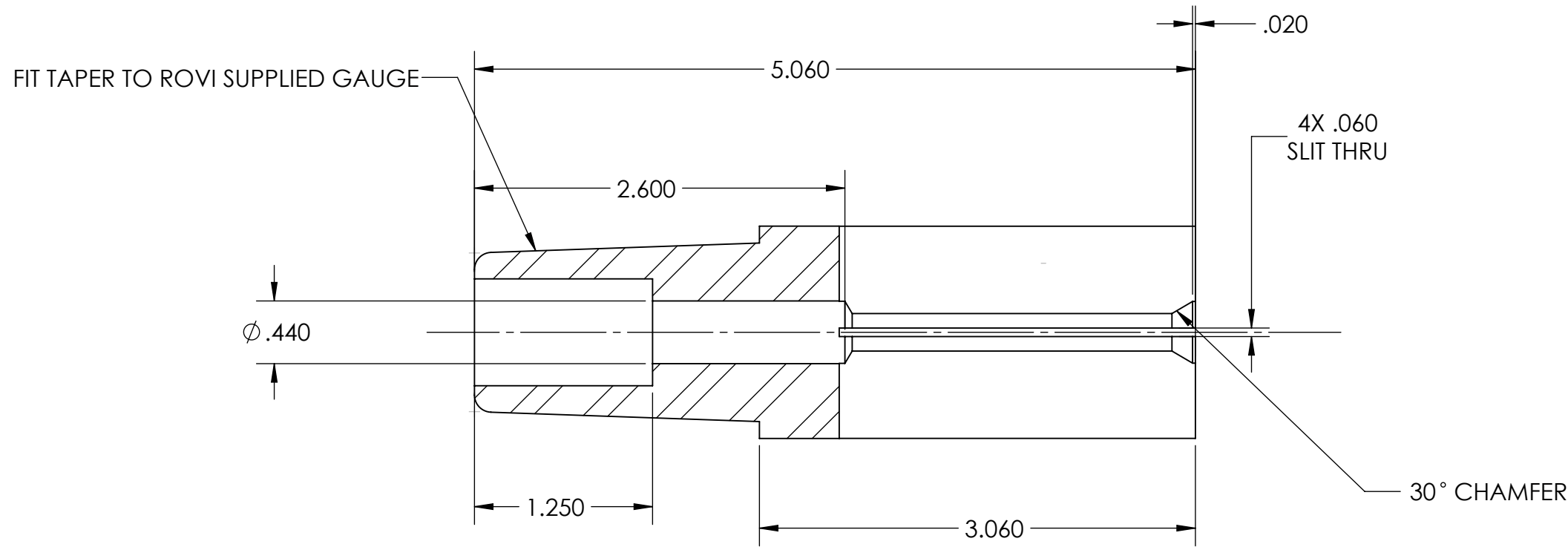

SECTION A-A
SCALE 1 : 1

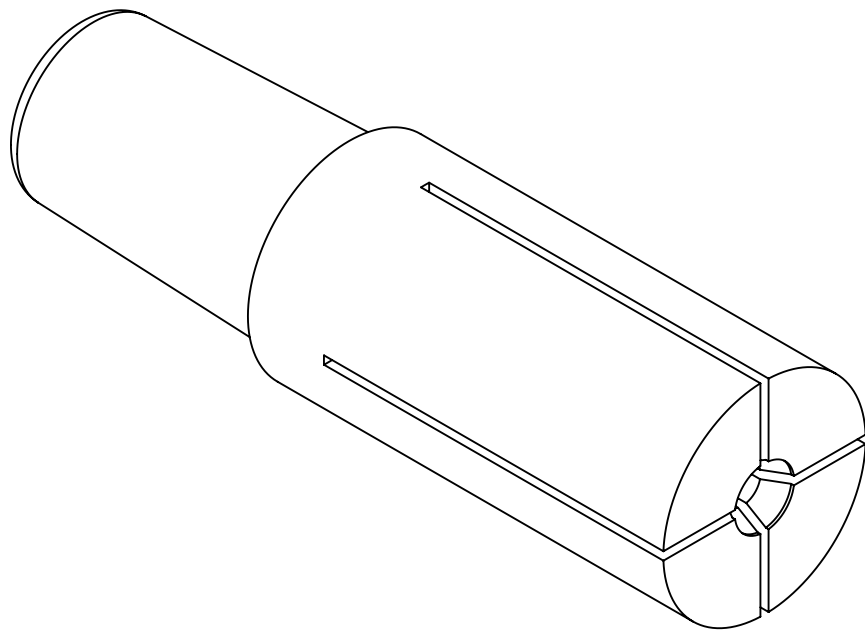

PROPRIETARY AND CONFIDENTIAL
THE INFORMATION CONTAINED IN THIS
DRAWING IS THE SOLE PROPERTY OF
ROVI PRODUCTS INC. ANY
REPRODUCTION IN PART OR AS A
WHOLE WITHOUT THE WRITTEN
PERMISSION OF ROVI PRODUCTS INC
IS PROHIBITED.

UNLESS OTHERWISE SPECIFIED:	NAME	DATE
DIMENSIONS ARE IN INCHES	DRAWN R. PEREZ	09/03/22
ANGULAR $\pm .5^\circ$	CHECKED	
TWO PLACE DECIMAL $\pm .01$	ENG APPR.	
THREE PLACE DECIMAL $\pm .003$	MFG APPR.	
FILLET RADII .015 MAX	Q.A.	
BREAK CORNERS .005/.010		
ALL ϕ CONC WITHIN .005 T.I.R.		
SURFACE FINISH 125/	THIRD ANGLE PROJECTION	
INTERPRET DRAWING PER: ASME Y14.5-2009		
DO NOT SCALE DRAWING		

rovi PRODUCTS INCORPORATED		ROVI PRODUCTS INC 4648 RUNWAY ST #B SIMI VALLEY, CA 93063	
TITLE: EXPANDING COLLET, KEY DIMENSIONS			
SIZE	DWG. NO.	REV	
B	1.5X3-4	---	
SCALE: 1:1	WEIGHT: 1.776 LBS	SHEET 1 OF 1	

4

3

2

1