

4

3

2

1

REVISION HISTORY

REV	DESCRIPTION	APPROVED	DATE
-			

FIT TAPER TO ROVI SUPPLIED GAUGE

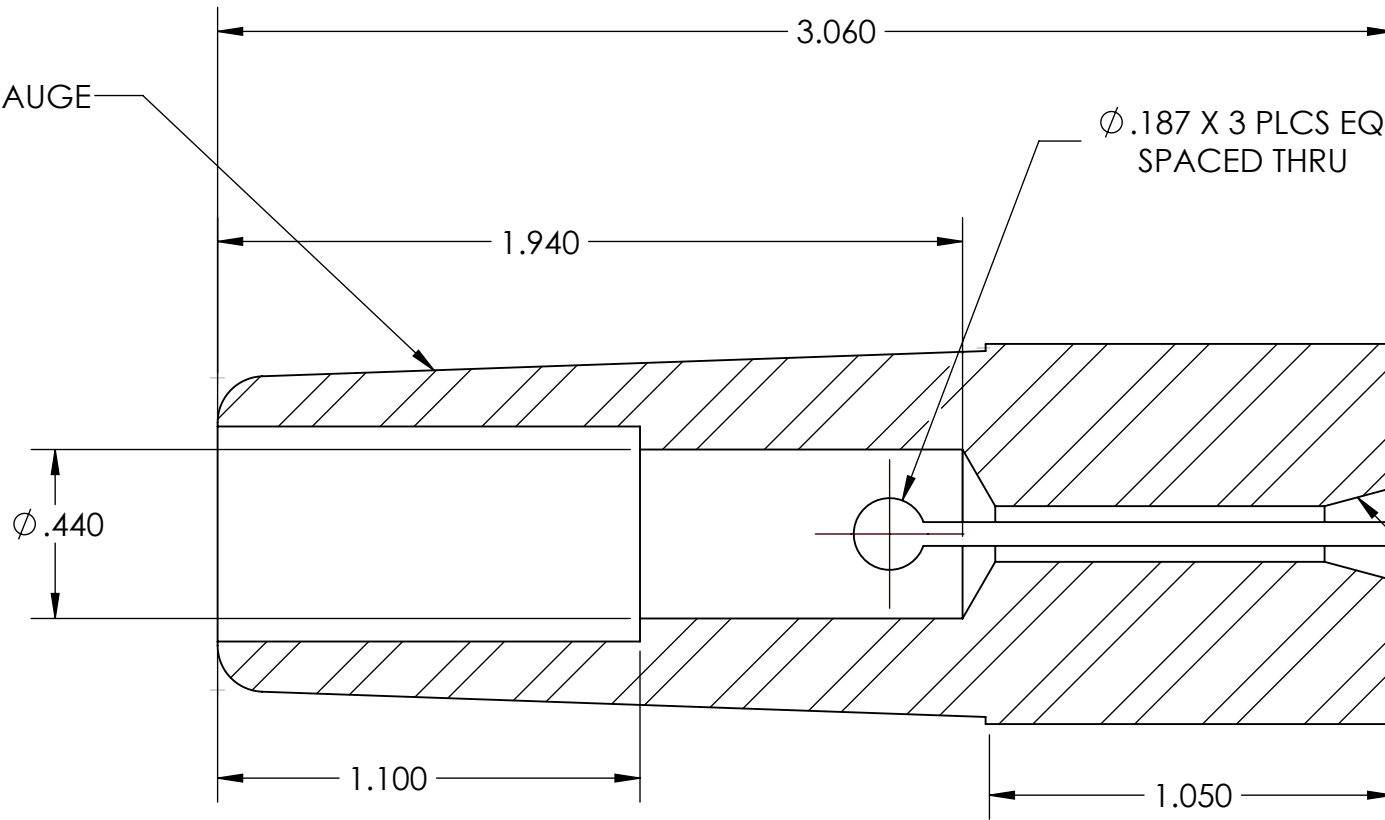

3X .062
SLIT THRU ONE WALL

30° CHAMFER

SECTION A-A
SCALE 2 : 1

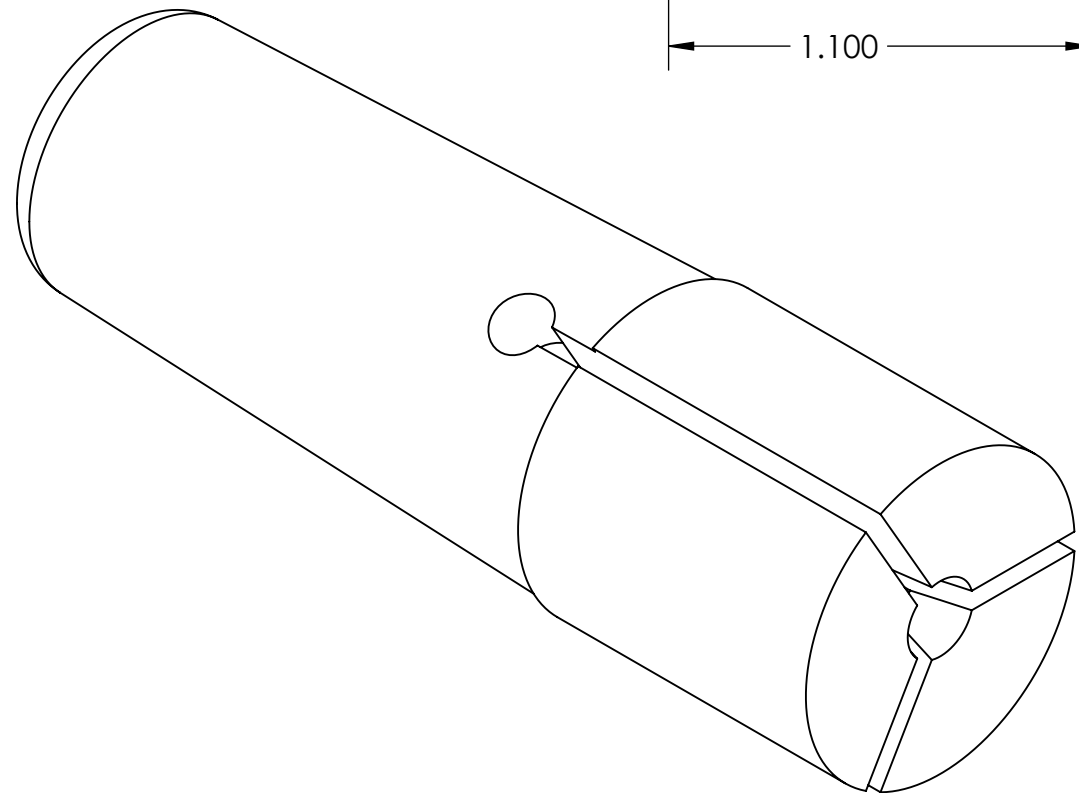
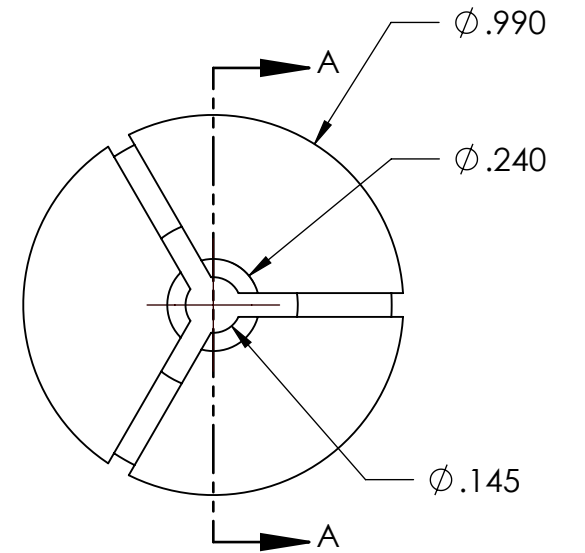

UNLESS OTHERWISE SPECIFIED:		NAME	DATE
DIMENSIONS ARE IN INCHES		DRAWN R. PEREZ	09/03/22
ANGULAR	±.5°	CHECKED	
TWO PLACE DECIMAL	±.01	ENG APPR.	
THREE PLACE DECIMAL	±.003	MFG APPR.	
FILLET RADII	.015 MAX	Q.A.	
BREAK CORNERS	.005/.010		
ALL Ø CONC WITHIN .005 T.I.R.			

rovi PRODUCTS INCORPORATED
 ROVI PRODUCTS INC
 4648 RUNWAY ST #B
 SIMI VALLEY, CA 93063

TITLE:
 EXPANDING COLLET, KEY
 DIMENSIONS

PROPRIETARY AND CONFIDENTIAL
 THE INFORMATION CONTAINED IN THIS
 DRAWING IS THE SOLE PROPERTY OF
 ROVI PRODUCTS INC. ANY
 REPRODUCTION IN PART OR AS A
 WHOLE WITHOUT THE WRITTEN
 PERMISSION OF ROVI PRODUCTS INC
 IS PROHIBITED.

SURFACE FINISH 125/
 INTERPRET DRAWING PER:
 ASME Y14.5-2009
 DO NOT SCALE DRAWING

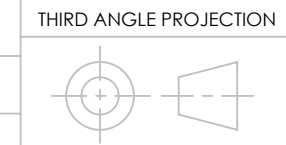

SIZE	DWG. NO.	REV
B	1X1-26HT	---
SCALE: 2:1	WEIGHT: 0.426 LBS	SHEET 1 OF 1

4

3

2

1

B

B

A

A