

4

3

2

1

REVISION HISTORY			
REV	DESCRIPTION	APPROVED	DATE
-			

FIT TAPER TO ROVI SUPPLIED GAUGE

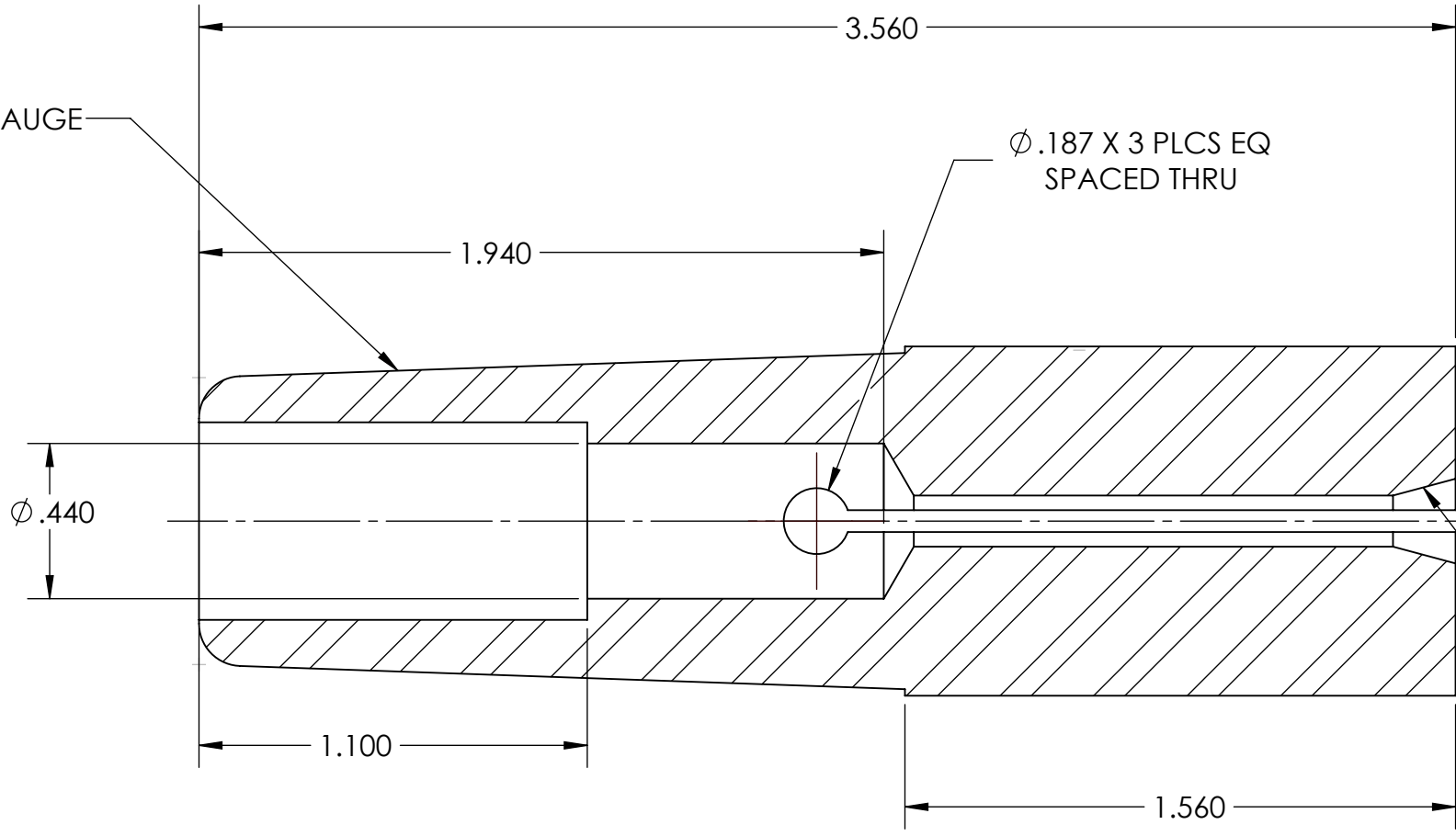

Ø.187 X 3 PLCS EQ SPACED THRU

3X .062 SLIT THRU ONE WALL

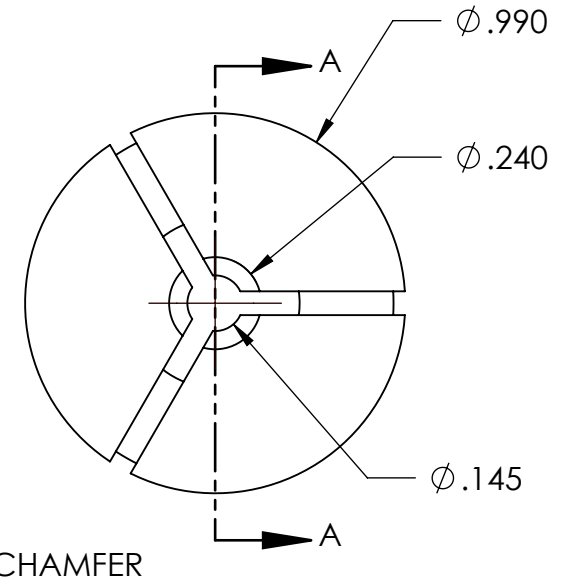

30° CHAMFER

SECTION A-A  
SCALE 2 : 1

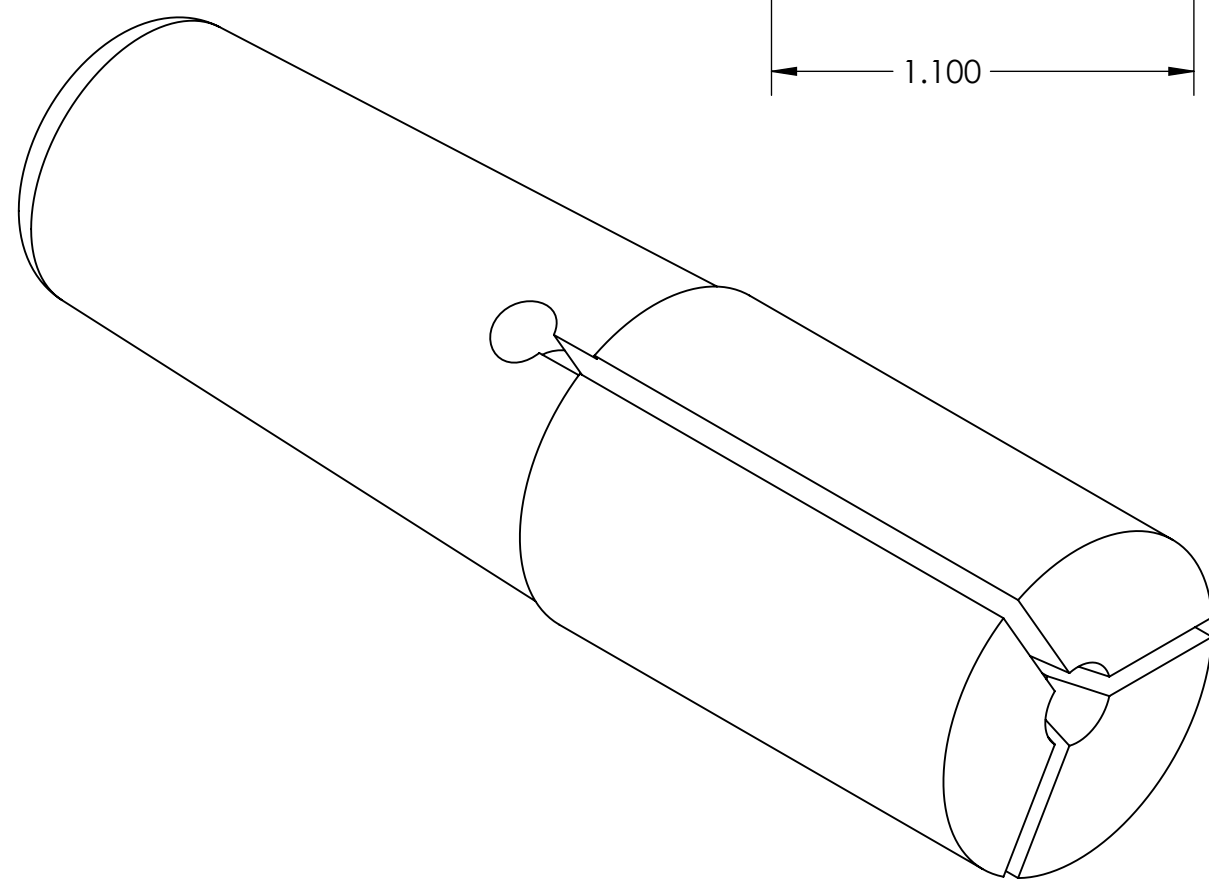

UNLESS OTHERWISE SPECIFIED:		NAME	DATE
DIMENSIONS ARE IN INCHES		DRAWN R. PEREZ	09/03/22
ANGULAR ±.5°	TWO PLACE DECIMAL ±.01	CHECKED	
THREE PLACE DECIMAL ±.003	FILLET RADII .015 MAX	ENG APPR.	
BREAK CORNERS .005/.010		MFG APPR.	
		Q.A.	
ALL Ø CONC WITHIN .005 T.I.R.		THIRD ANGLE PROJECTION	
SURFACE FINISH 125/√			
INTERPRET DRAWING PER: ASME Y14.5-2009			
DO NOT SCALE DRAWING			

PROPRIETARY AND CONFIDENTIAL  
 THE INFORMATION CONTAINED IN THIS DRAWING IS THE SOLE PROPERTY OF ROVI PRODUCTS INC. ANY REPRODUCTION IN PART OR AS A WHOLE WITHOUT THE WRITTEN PERMISSION OF ROVI PRODUCTS INC IS PROHIBITED.

**rovi** PRODUCTS INCORPORATED  
 ROVI PRODUCTS INC  
 4648 RUNWAY ST #B  
 SIMI VALLEY, CA 93063

TITLE:  
 EXPANDING COLLET, KEY DIMENSIONS

SIZE	DWG. NO.	REV
<b>B</b>	1X1.5-26HT	---
SCALE: 2:1	WEIGHT: 0.522 LBS	SHEET 1 OF 1

4

3

2

1

B

B

A

A