

4

3

2

1

REVISION HISTORY			
REV	DESCRIPTION	APPROVED	DATE
-			

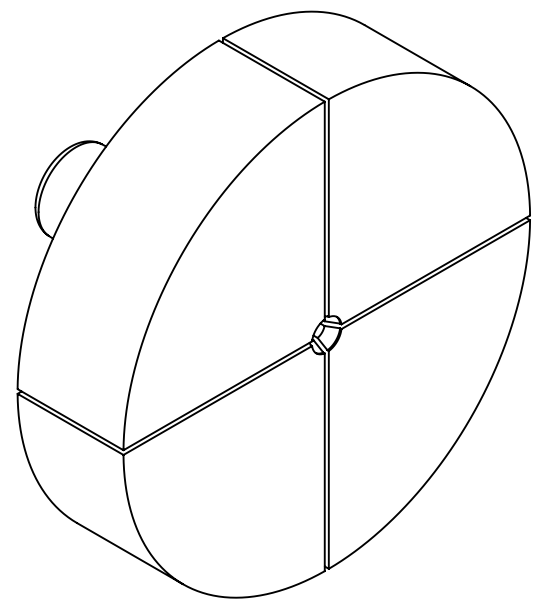
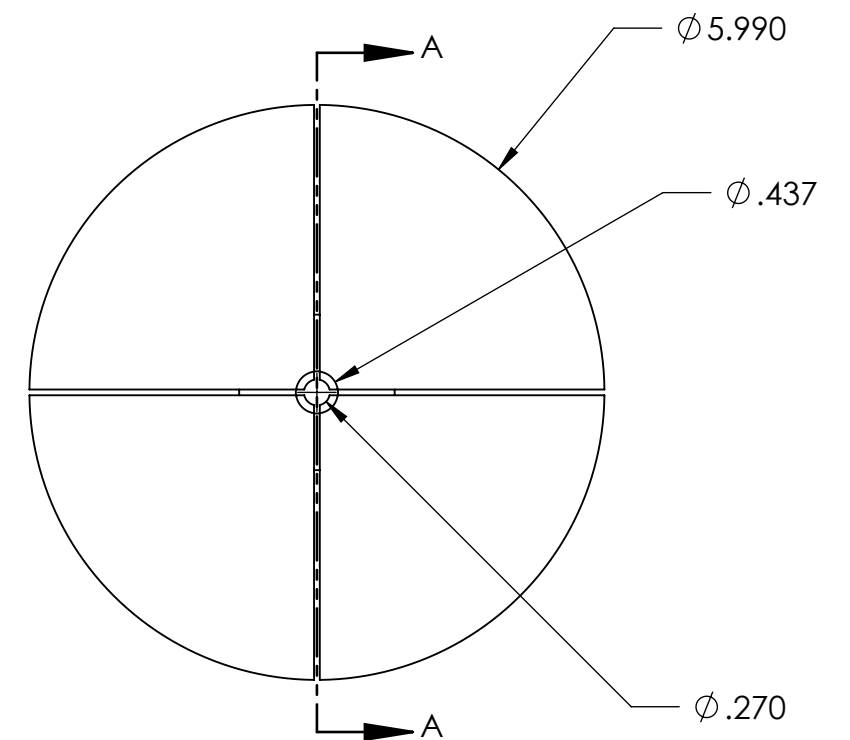
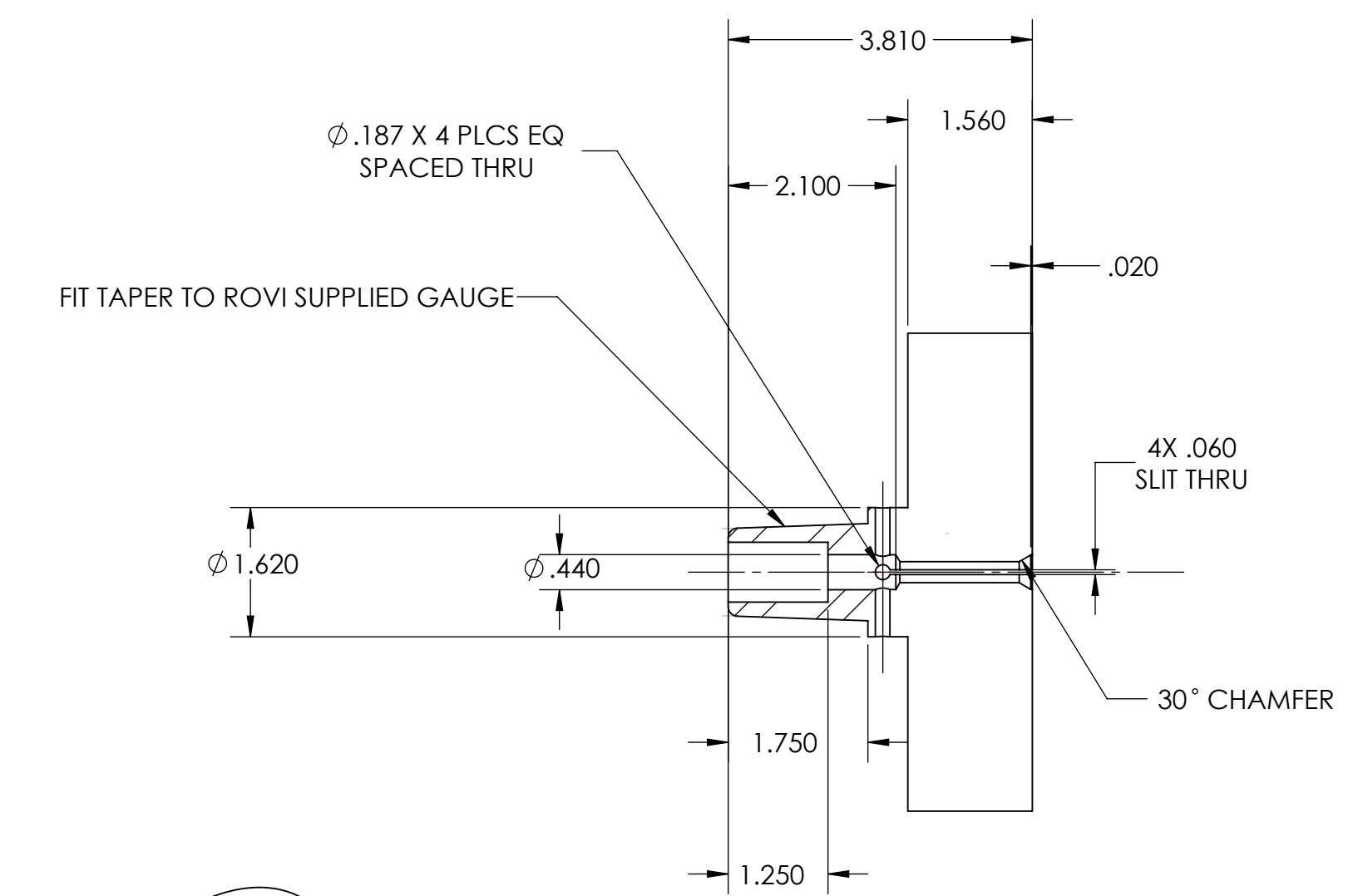

SECTION A-A  
SCALE 1 : 2

UNLESS OTHERWISE SPECIFIED:	NAME	DATE
DIMENSIONS ARE IN INCHES	DRAWN R. PEREZ	09/03/22
ANGULAR ±.5°	CHECKED	
TWO PLACE DECIMAL ±.01	ENG APPR.	
THREE PLACE DECIMAL ±.003	MFG APPR.	
FILLET RADII .015 MAX	Q.A.	
BREAK CORNERS .005/.010		
ALL Ø CONC WITHIN .005 T.I.R.		
SURFACE FINISH 125/√	THIRD ANGLE PROJECTION	
INTERPRET DRAWING PER: ASME Y14.5-2009		
DO NOT SCALE DRAWING		

**rovi** PRODUCTS INCORPORATED  
 ROVI PRODUCTS INC  
 4648 RUNWAY ST #B  
 SIMI VALLEY, CA 93063

TITLE:  
**EXPANDING COLLET, KEY DIMENSIONS**

SIZE	DWG. NO.	REV
<b>B</b>	6X1.5-4	---

SCALE: 1:1    WEIGHT: 12.737 LBS    SHEET 1 OF 1

PROPRIETARY AND CONFIDENTIAL  
 THE INFORMATION CONTAINED IN THIS DRAWING IS THE SOLE PROPERTY OF ROVI PRODUCTS INC. ANY REPRODUCTION IN PART OR AS A WHOLE WITHOUT THE WRITTEN PERMISSION OF ROVI PRODUCTS INC IS PROHIBITED.

4

3

2

1

B

B

A

A