

ROYAL QUICK-GRIP EMERGENCY COLLETS BORING INSTRUCTIONS

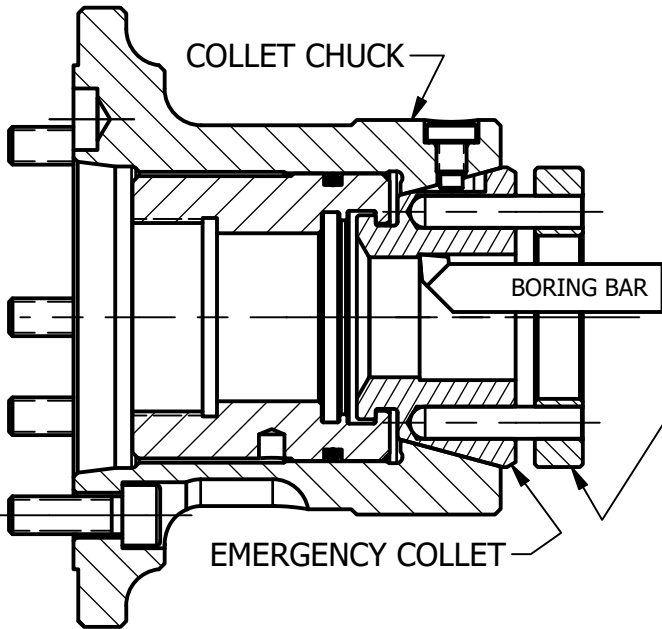

THRU/STEP BORING USING A ROYAL BORING FIXTURE

- 1 - INSTALL EMERGENCY COLLET IN CHUCK
- 2 - REDUCE CLAMPING PRESSURE TO A MINIMUM
- 3 - INSTALL BORING FIXTURE AND CLAMP
- 4 - BORE TO SIZE

ROYAL BORING FIXTURE

- QG-32 P/N 44399
- QG-42 P/N 44082
- QG-52 P/N 44094
- QG-65 P/N 44083
- QG-80 P/N 44088

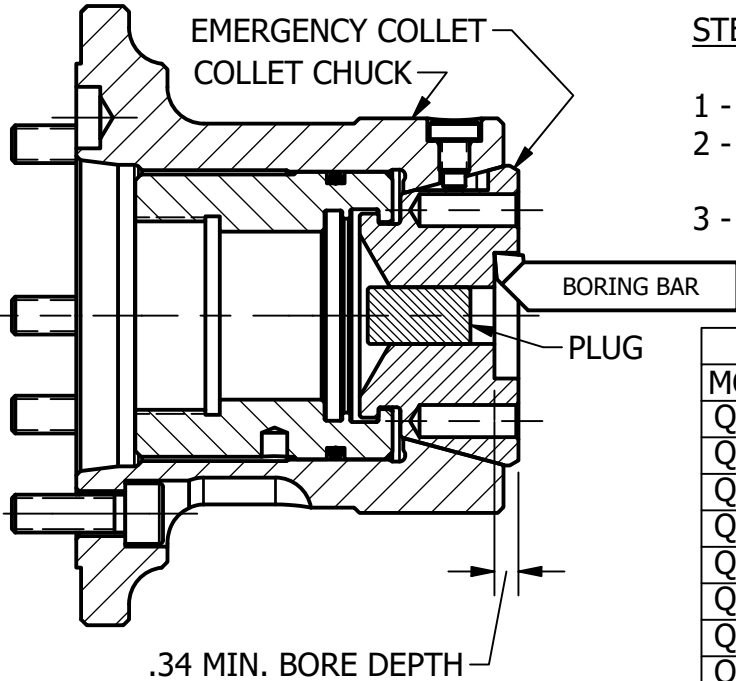

STEP BORING USING A PLUG

- 1 - INSTALL EMERGENCY COLLET IN CHUCK
- 2 - INSERT PROPER DIAMETER PLUG (NOT SUPPLIED) INTO REAR OF COLLET, CLAMP
- 3 - BORE TO SIZE

ROYAL QUICK-GRIP EMERGENCY COLLETS

MODEL	PLUG DIA. +0/-.010"	P/N	MAX DIA.
QG-32	5mm (.197")	44397	1.250
QG-42	5mm (.197")	44187	1.625
QG-42	15mm (.591")	44188	1.625
QG-42	30mm (1.181")	44189	1.625
QG-52	8mm (.315")	44395	2.000
QG-52	15mm (.591")	44396	2.000
QG-65	8mm (.315")	44353	2.625
QG-65	20mm (.787")	44354	2.625
QG-65	30mm (1.181")	44355	2.625
QG-65	40mm (1.575")	44356	2.625
QG-80	8mm (.315")	44360	3.250
QG-80	20mm (.787")	44361	3.250
QG-80	40mm (1.575")	44362	3.250
QG-80	60mm (2.362")	44363	3.250

WARNINGS:

- * MACHINE IN AN ENCLOSED MACHINE
- * ADJUST SPEEDS & FEEDS FOR BORING AN INTERRUPTED CUT IN SEMI-HARD STEEL (ONLY THE COLLET TAPER IS HEAT TREATED)
- * DO NOT BORE LARGER THAN THE MAX. DIAMETER. CONTACT ROYAL PRODUCTS FOR COUNTER BORE GUIDELINES (DOCUMENT R220621)

QUESTIONS, COMMENTS OR CONCERNS? PLEASE VISIT WWW.ROYALPRODUCTS.COM

ROYAL PRODUCTS
200 OSER AVE.
HAUPPAUGE NY 11788

R220565 rev.B