

Style-S Master Collets and Pads Instruction Sheet B-038-B

Installing Hardinge[®] Style-S Master Collets and Pads

Collet Pads can be changed from the face of the collet without having to remove the master collet.

Insert the Master Collet. Clean the Pads and the pad seat in the Master Collet and apply the Pads. Feed the bar stock through the collet and grip the stock using the proper tension. Tighten the pad clamp securely by using firm finger pressure on the proper size spline wrench as shown in the illustration. It is not necessary to use an extension on the wrench.

Do NOT remove pad clamp screws from the master collet when removing the Pads. Loosen the screws two turns with the wrench and push the clamp assembly into the collet with finger pressure. (This clears the rear clamp dovetail from the rear dovetail on the pad.)

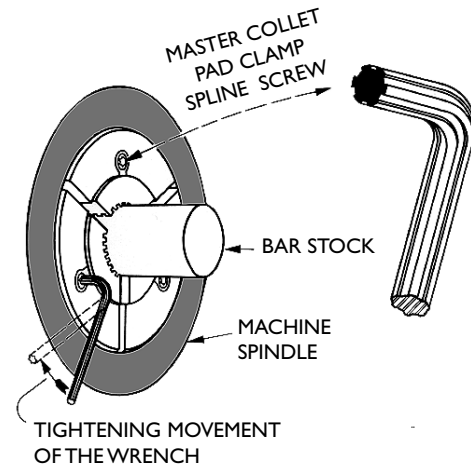

| Style "S" Wrenches | Size | For Pads | Part Number |
|--------------------|-------|------------------------------|-------------------|
| L Wrench: B Spline | .111" | S10, S12, S15, S16, S20, S26 | 7637-00-00-000000 |
| L Wrench: C Spline | .145" | S22*, S30, S35, S40, S50 | 7639-00-00-000000 |

*For Warner & Swasey 2 1/4" and Miyano 1 1/4" capacity, order the .111" wrench