

MATERIAL LIST				
ITEM	QTY.	DESCRIPTION	INV. #	DWG. #
1	1	UNIVERSAL BASE PLATE	AT-3005	9516.ipt
2	1	FRONT SHEAVE MOUNTING BRACKET	AT-3001	9492.ipt
3	1	BACK SHEAVE MOUNTING BRACKET	AT-3002	9495.ipt
4	2	BUSHING 1.003 OD X .876" ID X .5	AT-0150	AT-150.ipt
5	1	SPINDLE	AT-2003-000	8986.ipt
6	1	CLUTCH PLATE	AT-2009-400	8992.ipt
7	2	SHEAVE	AT-2008-400	8991.ipt
8	2	CLUTCH PAD	AT-0123-001	AT-0123-001.ipt
9	1	IDLER BEARING	AT-0121	629_ZZ.iam
10	1	SHEAVE IDLER	AT-2006-000	8989.ipt
11	1	SHEAVE PULLEY	AT-2007-000	8990.ipt
12	1	BACKING PLATE SLIDE	AT-2011-336	8949.ipt
13	1	SHAFT IDLER SHEAVE	AT-3006	11544.ipt
14	1	COMPRESSION SPRING	AT-0138	AT-0138.ipt
15	1	BACKING PLATE SHAFT	AT-2001-000	8984.ipt
16	1	DOWEL PIN .250 DIA X .875"	AT-0137	AT-0137.ipt
17	1	BACKING PLATE	AT-2004-336	8987.ipt
18	1	1/2" JACOBS CHUCK K3	AT-0159-001	AT-0159-001.ipt
19	2	STOP PLATE	AT-2000-210	8983.ipt
20	2	3 ARM KNOB	AT-0007	AT-0007.ipt
21	2	DELTRIN WASHER	AT-1118-010	AT-1118-010.ipt
22	1	SPACER, HOUSING	AT-3004	9551.ipt
23	1	MOTOR, 1/3 HP , 115 V 60 HZ, 1 PH	AT-0126-000	AT-0126-000.iam
24	1	V-BELT	AT-0124	at-0124.ipt
25	1	BELT GUARD COVER	AT-0125-02	10589.ipt
26	4	Helical Spring Lock Washer 5/16 Hi-Collar	AT-0201	0.3125.ipt
27	8	Hexagon Socket Head Cap Screw 5/16 - 18 UNC - 1	AT-0153	5_16-1-UNC.ipt
28	1	Hex Flange Nut 3/8-24 Plated	AT-0131	3_8-UNC.ipt
29	1	CAUTION LABEL "STOP MOTOR,..."	AT-0147	AT-0147.ipt
30	1	CAUTION LABEL "ALWAYS USE..."	AT-0146	AT-0146.ipt
31	4	FLAT WASHER, .25" PLATED	AT-0133	AT-0133.ipt
32	4	Helical Spring Lock Washer 5/16"	AT-0132	0.3125.ipt
34	4	HEX HD CAP SCREW 5/16-18 X .625"	AT-0128	AT-0128.ipt
35	2	SET SCREW 5/16-18 X .375" LG	AT-0130	AT-0130.ipt
36	4	Cross Recessed Pan Hd Mach. Screw 10-24 X .25"	AT-0135	#10-0.25-UNC.ipt
37	1	NYLON CABLE CLAMP	AT-0152	086-663.ipt
38	1	SCREW, #6-32 X .75 BUTT HEAD SOCKET CAP	AT-0167	AT-0167.ipt
39	1	CORD W/ INLINE SWITCH, 110 VOLTS	AT-0139-001	AT-0139-001.ipt
40	1	Cross Rec. Pan Head Mach. Screw No. 8 - 32 - 3/8	AT-0151	#8-0.375-UNC.ipt
41	2	Wire End Quick Disconnect .059" AWG 22-18 4X423	AT-0141	9517.iam
42	1	WIRE END SPADE TONGUE, SIZE 10	AT-0142	9517.iam
43	1	SETSCREW CUP PT 10-24 X 1.25 SOC	AT-0168	AT-0168.ipt
44	1	SERIAL NUMBER TAG	8114	8114.ipt

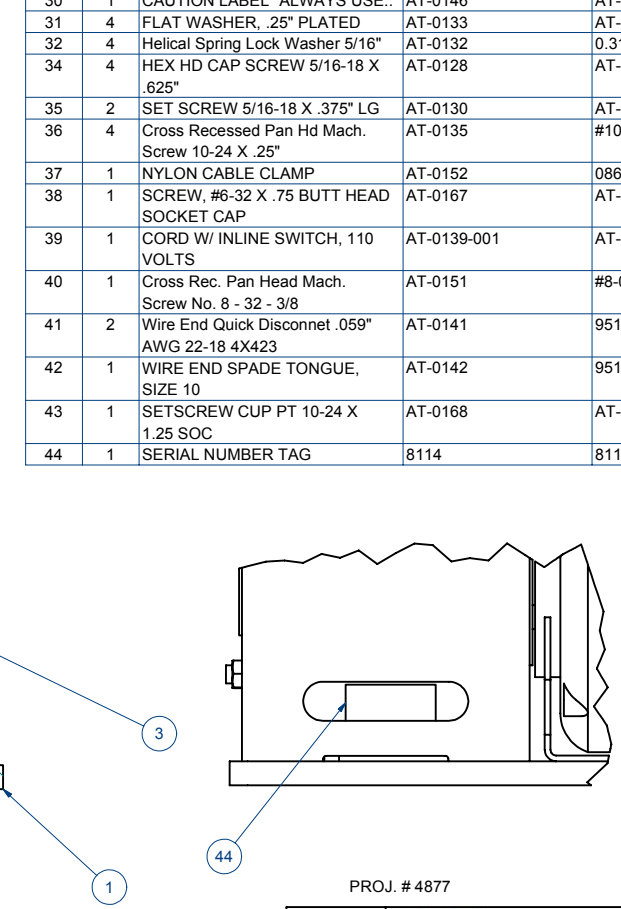
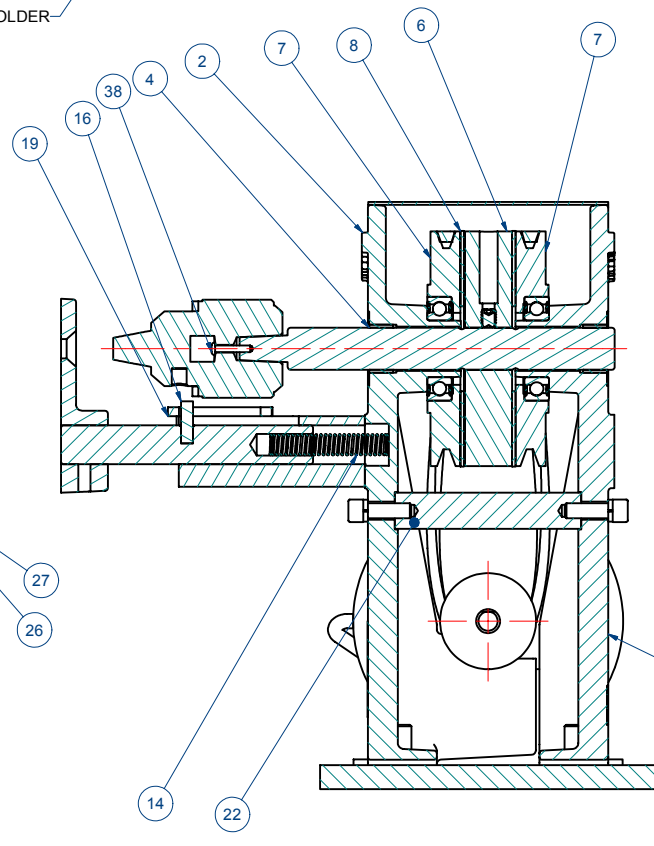
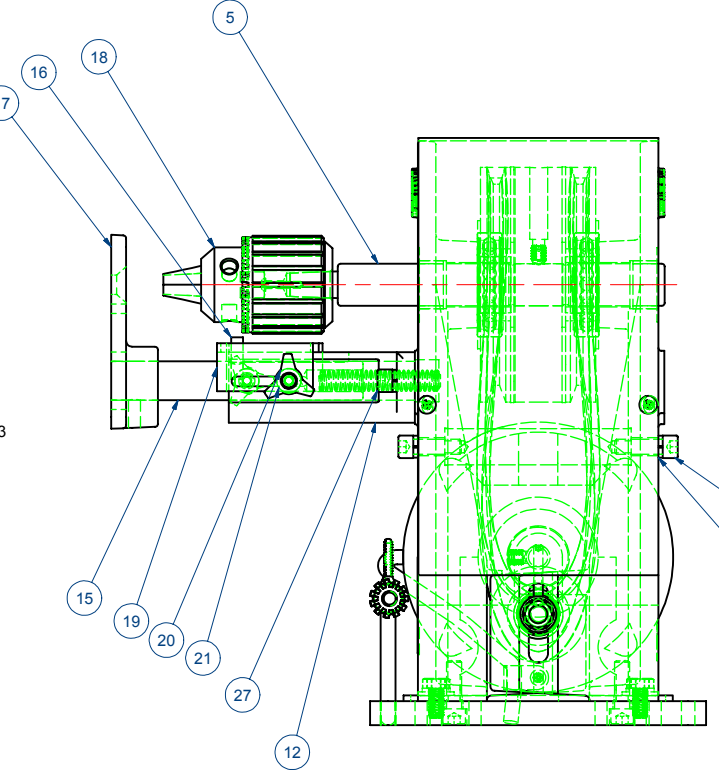
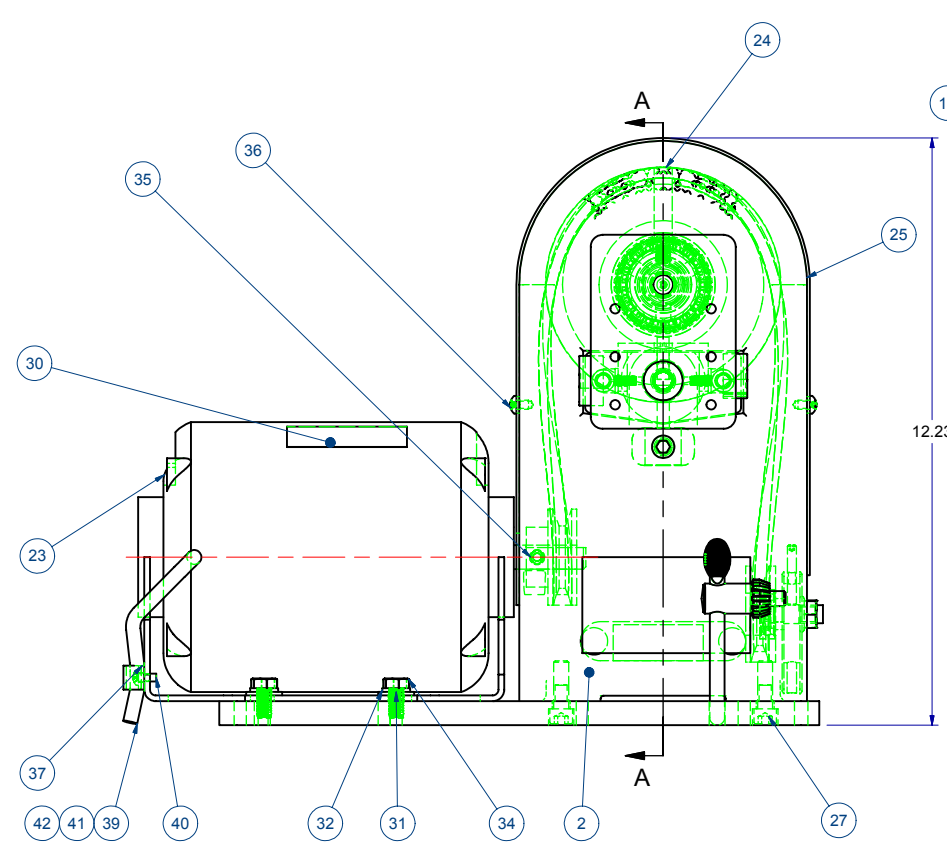

SECTION A-A
SCALE 1/2

PROJ. # 4877

PART I.D. AT-2010A	ISCO Manufacturing Solutions	9517.idw
TOLERANCES EXCEPT AS NOTED XX=+/- .015" .XXX=+/- .005"	TITLE ASSEMBLY-SINGLE SPEED, 1/2" CHUCK ACCU-TAPPER	WWW.ISCOMACH.COM
ANGE +/- 1'	DATE 9/6/2006	SCALE D

REV	DESCRIPTION	DATE	SCALE	SIZE	DWG NO	REV
A	ADDED S/N PLATE	10-1-08				
	REVISION HISTORY					